

104 Ch. 9 Problems**Multiple Choice**

Identify the choice that best completes the statement or answers the question.

- _____ 1. Find the arc length of the curve $3y = 4x$ from $(3, 4)$ to $(9, 12)$.
- | | |
|-------|-------|
| a. 13 | e. 9 |
| b. 10 | f. 15 |
| c. 8 | g. 11 |
| d. 14 | h. 12 |
- _____ 2. Find the arc length of the curve $y^2 = x^3$ from $(0, 0)$ to $(\frac{1}{4}, \frac{1}{8})$.
- | | |
|---------------------|---------------------|
| a. $\frac{65}{216}$ | e. $\frac{61}{216}$ |
| b. $\frac{29}{108}$ | f. $\frac{31}{108}$ |
| c. $\frac{59}{216}$ | g. $\frac{35}{108}$ |
| d. $\frac{37}{108}$ | h. $\frac{71}{216}$ |
- _____ 3. Find the arc length of the curve $y = \sqrt{4 - x^2}$, $-2 \leq x \leq 2$.
- | | |
|---------------------|---------------------|
| a. 2π | e. $\frac{3\pi}{2}$ |
| b. $\frac{3\pi}{4}$ | f. $\frac{\pi}{2}$ |
| c. π | g. $\frac{9\pi}{4}$ |
| d. $\frac{7\pi}{4}$ | h. $\frac{5\pi}{4}$ |
- _____ 4. Find the arc length of the curve $y = \ln(\cos x)$, $0 \leq x \leq \frac{\pi}{3}$.
- | | |
|------------------------|------------------------|
| a. $\ln(2 + \sqrt{2})$ | e. $\ln(1 + \sqrt{2})$ |
| b. $\ln(1 + \sqrt{3})$ | f. $\ln(2 + \sqrt{3})$ |
| c. $\ln(2 - \sqrt{2})$ | g. $\ln(\sqrt{3} - 1)$ |
| d. $\ln(2 - \sqrt{3})$ | h. $\ln(\sqrt{2} - 1)$ |

- _____ 5. Find the length of the curve $y = \frac{2}{3}(x-4)^{\frac{3}{2}}$, $7 \leq x \leq 12$.
- | | |
|-------------------|-------------------|
| a. 19 | e. $\frac{19}{2}$ |
| b. $\frac{65}{2}$ | f. $\frac{38}{3}$ |
| c. $\frac{55}{2}$ | g. 38 |
| d. 55 | h. 65 |
- _____ 6. Find the length of the curve $x = t^3 - 3t^2$, $y = t^3 + 3t^2$, $0 \leq t \leq \sqrt{5}$.
- | | |
|--------------------|------------------|
| a. 81 | e. 57 |
| b. $\sqrt{5}$ | f. $\sqrt{15}$ |
| c. $\frac{171}{2}$ | g. $105\sqrt{5}$ |
| d. $\sqrt{28}$ | h. $\sqrt{30}$ |
- _____ 7. Find the length of the curve $x = \sin^3 t$, $y = \cos^3 t$, $0 \leq t \leq 2\pi$.
- | | |
|------------------|-----------|
| a. 0 | e. 12 |
| b. $\frac{3}{2}$ | f. 6 |
| c. 2 | g. 4 |
| d. π | h. 2π |
- _____ 8. Find the length of the curve $x = \frac{1}{3}(2t+1)^{\frac{3}{2}}$, $y = \frac{1}{2}t^2$, $0 \leq t \leq 4$.
- | | |
|-------|------|
| a. 0 | e. 1 |
| b. 8 | f. 6 |
| c. 2 | g. 4 |
| d. 12 | h. 9 |
- _____ 9. Give a definite integral representing the length of the parametric curve $x = t^3$, $y = t^4$, $0 \leq t \leq 1$.
- | | |
|------------------------------------|--------------------------------------|
| a. $\int_0^1 (t^3 + t^4) dt$ | e. $\int_0^1 \sqrt{9t^4 + 16t^6} dt$ |
| b. $\int_0^1 \sqrt{t^3 + t^4} dt$ | f. $\int_0^1 \sqrt{4t^4 + 9t^6} dt$ |
| c. $\int_0^1 \sqrt{1 + 3t^2} dt$ | g. $\int_0^1 \sqrt{t^5 + t^7} dt$ |
| d. $\int_0^1 \sqrt{t^2 + 4t^3} dt$ | h. $\int_0^1 \sqrt{8t^6 + 6t^8} dt$ |

_____ 10. Find the length of the curve $x = \frac{1}{3}(y^2 + 2)^{\frac{3}{2}}$, $1 \leq y \leq 2$

- | | |
|-------------------|-------------------|
| a. 0 | e. 1 |
| b. $\frac{7}{3}$ | f. $\frac{5}{3}$ |
| c. 2 | g. 4 |
| d. $\frac{14}{3}$ | h. $\frac{10}{3}$ |

_____ 11. Give a definite integral representing the length of the curve $y = \frac{1}{x}$, $1 \leq x \leq 2$.

- | | |
|---|---|
| a. $\int_1^2 \sqrt{1 + \frac{1}{x^2}} dx$ | e. $\int_1^2 \frac{1}{x^2} dx$ |
| b. $\int_1^2 \sqrt{1 + \frac{1}{x^4}} dx$ | f. $\int_1^4 \sqrt{1 + \frac{1}{x^4}} dx$ |
| c. $\int_1^2 \sqrt{1 + (\ln x)^2} dx$ | g. $\int_1^2 x \sqrt{1 + \frac{1}{x^2}} dx$ |
| d. $\int_1^2 \sqrt{1 + \frac{1}{x}} dx$ | h. $\int_1^4 \frac{1}{x^4} dx$ |

_____ 12. Find the center of mass of the linear system $m_1 = 1$, $m_2 = 9$, $m_3 = 6$; $x_1 = -3$, $x_2 = -1$, $x_3 = 1$.

- | | |
|-------------------|-------------------|
| a. $-\frac{3}{8}$ | e. $-\frac{3}{4}$ |
| b. $\frac{3}{8}$ | f. $\frac{3}{4}$ |
| c. 6 | g. -6 |
| d. $\frac{2}{3}$ | h. $-\frac{2}{3}$ |

_____ 13. Find the center of mass of the linear system $m_1 = 2$, $x_1 = -3$, $m_2 = 8$; $x_2 = -1$, $m_3 = 3$, $x_3 = 1$, $m_4 = 5$, $x_4 = 4$.

- | | |
|-------------------|-------------------|
| a. 9 | e. $\frac{2}{3}$ |
| b. $\frac{1}{2}$ | f. $-\frac{2}{3}$ |
| c. $-\frac{1}{2}$ | g. -9 |
| d. 0 | h. 18 |

- _____ 14. Find the center of mass of the system $m_1 = 5$, $P_1(-3, 1)$, $m_2 = 9$; $P_2 = (-1, -1)$, $m_3 = 6$, $P_3 = (1, 1)$, $m_4 = 8$, $P_4(3, -2)$.
- | | |
|--|----------------|
| a. $\left(\frac{3}{14}, -\frac{1}{2}\right)$ | e. $(6, -14)$ |
| b. $\left(-\frac{1}{2}, \frac{3}{14}\right)$ | f. $(-14, 6)$ |
| c. $\left(\frac{3}{14}, \frac{1}{2}\right)$ | g. $(14, -6)$ |
| d. $\left(-\frac{3}{14}, \frac{1}{2}\right)$ | h. $(-14, -6)$ |
- _____ 15. Find the x -coordinate of the centroid of the region bounded by the graphs $y = \sqrt[3]{x}$, $x = 8$, and the x -axis.
- | | |
|--------------------|-------------------|
| a. 8 | e. 4 |
| b. $\frac{16}{7}$ | f. $\frac{32}{7}$ |
| c. $\frac{7}{16}$ | g. $\frac{7}{32}$ |
| d. $\frac{224}{9}$ | h. $\frac{2}{3}$ |
- _____ 16. Find the y -coordinate of the centroid of the region bounded by the curves $y = x^2$, $y = 1$
- | | |
|---------|---------|
| a. 0.85 | e. 0.75 |
| b. 0.70 | f. 0.55 |
| c. 0.60 | g. 0.80 |
| d. 0.50 | h. 0.65 |
- _____ 17. Find the x -coordinate \bar{x} at the centroid of the region bounded by the x -axis and the lines $y = 3x$, $x = 2$.
- | | |
|-------------------|-------------------|
| a. $\frac{4}{3}$ | e. $\frac{11}{7}$ |
| b. $\frac{7}{6}$ | f. $\frac{11}{6}$ |
| c. $\frac{10}{7}$ | g. $\frac{5}{4}$ |
| d. $\frac{5}{3}$ | h. $\frac{7}{4}$ |
- _____ 18. Suppose a company has estimated that the marginal cost of manufacturing x items is $c'(x) = 5 + 0.02x$ (measured in dollars per unit) with a fixed start-up cost of $c(0) = 10,000$. Find the cost of producing the first 500 items.
- | | |
|-------------|-------------|
| a. \$15,000 | e. \$25,000 |
| b. \$5,000 | f. \$6000 |
| c. \$10,000 | g. \$20,000 |
| d. \$17,500 | h. \$60,000 |

- _____ 19. Suppose a company has estimated that the marginal cost of manufacturing x pairs of a new line of jeans is $c'(x) = 3 + 0.002x + 0.000006x^2$ (measured in dollars per pair) with a fixed start-up cost of $c(0) = 2000$. Find the cost of producing the first 1000 pair of jeans.
- | | |
|-------------|-------------|
| a. \$2000 | e. \$3000 |
| b. \$4000 | f. \$5000 |
| c. \$6000 | g. \$8000 |
| d. \$10,000 | h. \$15,000 |
- _____ 20. The demand function for a certain commodity is $p(x) = 4 - \frac{1}{30}x$. Find the consumer surplus when the sales level is 30.
- | | |
|-------|-------|
| a. 90 | e. 30 |
| b. 45 | f. 60 |
| c. 15 | g. 20 |
| d. 70 | h. 80 |
- _____ 21. If the demand function for a certain commodity is $p(x) = 4 - \frac{x}{30}$ and the consumer surplus is 15, what should be the production level?
- | | |
|-------|-------|
| a. 90 | e. 30 |
| b. 45 | f. 60 |
| c. 15 | g. 20 |
| d. 70 | h. 80 |
- _____ 22. If the demand function for a certain commodity is $p(x) = 4 - \frac{x}{30}$ and the consumer surplus is 15, what should be the sale price?
- | | |
|--------|--------|
| a. 1 | e. 3.3 |
| b. 4 | f. 6 |
| c. 1.5 | g. 2 |
| d. 2.5 | h. 3 |
- _____ 23. The demand function for a certain commodity is $p(x) = \frac{1800}{(x+5)^2}$. Find the consumer surplus when the selling price is \$18?
- | | |
|--------|--------|
| a. 135 | e. 270 |
| b. 30 | f. 40 |
| c. 45 | g. 90 |
| d. 360 | h. 180 |
- _____ 24. A supply function is given by $p_s(x) = 5 + \frac{1}{10}x$, where x is the number of units produced. Find the producer surplus when the selling price is \$15.
- | | |
|---------|---------|
| a. 100 | e. 800 |
| b. 500 | f. 400 |
| c. 250 | g. 200 |
| d. 1000 | h. 2000 |

- _____ 25. A rental estate management company manages an apartment complex with 20 units. The manager estimates that all 20 units can be rented if the rent is \$150 per unit per month and that for each increase in rent of \$10, one apartment will be vacated. Find the consumer surplus when 5 apartments are vacated.
- | | |
|---------|---------|
| a. 3000 | e. 1125 |
| b. 2250 | f. 6000 |
| c. 1250 | g. 2500 |
| d. 1000 | h. 3500 |

- _____ 26. Find k so that the function $f(x) = \begin{cases} kx(1-x) & \text{if } 0 < x < 1 \\ 0 & \text{otherwise} \end{cases}$ can serve as the probability density function of a random variable X .

- | | |
|------------------|------|
| a. $\frac{1}{3}$ | e. 3 |
| b. $\frac{1}{6}$ | f. 6 |
| c. $\frac{1}{2}$ | g. 2 |
| d. 1 | h. 0 |

- _____ 27. Find k so that the function $f(x) = \begin{cases} \frac{k}{x(\ln x)^3} & \text{if } x > e \\ 0 & \text{otherwise} \end{cases}$ can serve as the probability density function of a random variable X .

- | | |
|------------------|------|
| a. $\frac{1}{3}$ | e. 3 |
| b. $\frac{1}{6}$ | f. 6 |
| c. $\frac{1}{2}$ | g. 2 |
| d. 1 | h. 0 |

____ 28. Let X be a continuous random variable with density function

$$f(X) = \begin{cases} c \cdot e^{-cX} & \text{if } X \geq 0 \\ 0 & \text{otherwise} \end{cases}$$

If the median of this distribution is $\frac{1}{3}$, then c is:

- | | |
|----------------------------------|----------------------------------|
| a. $\frac{1}{3} \ln \frac{1}{2}$ | e. 3 |
| b. $\frac{1}{3} \ln 2$ | f. $\frac{1}{3}$ |
| c. $2 \ln \frac{3}{2}$ | g. $2 \cdot \frac{\ln 3}{\ln 2}$ |
| d. $3 \ln 2$ | h. $3 \ln \frac{1}{2}$ |

____ 29. Let X be a continuous random variable with density function

$$p(X) = \begin{cases} \frac{1}{9} X(4-X) & \text{if } 0 \leq X \leq 3 \\ 0 & \text{otherwise} \end{cases}$$

What is the mean of X ?:

- | | |
|------------------|------------------|
| a. $\frac{4}{9}$ | e. $\frac{2}{3}$ |
| b. 1 | f. $\frac{1}{3}$ |
| c. $\frac{3}{2}$ | g. $\frac{7}{4}$ |
| d. $\frac{2}{9}$ | h. $\frac{9}{4}$ |

____ 30. Find c so that the following can serve as the probability density function of a random variable X :

$$f(X) = \begin{cases} c \cdot X \cdot e^{-4X^2} & \text{if } X \geq 0 \\ 0 & \text{otherwise} \end{cases}$$

- | | |
|------------------|-------------------|
| a. 8 | e. 1 |
| b. 4 | f. 16 |
| c. $\frac{1}{8}$ | g. $\frac{1}{16}$ |
| d. $\frac{1}{4}$ | h. 2 |

- _____ 31. Let $f(x) = 6x(1-x)$, $0 < x < 1$ be the probability density function of a random variable X . Find the mean of the probability density function f .
- | | |
|------------------|------|
| a. $\frac{1}{3}$ | e. 3 |
| b. $\frac{1}{6}$ | f. 6 |
| c. $\frac{1}{2}$ | g. 2 |
| d. 1 | h. 0 |
- _____ 32. Let $f(x) = 6x(1-x)$, $0 < x < 1$ be the probability density function of a random variable X . Find the median of the probability density function f .
- | | |
|------------------|------|
| a. $\frac{1}{3}$ | e. 3 |
| b. $\frac{1}{6}$ | f. 6 |
| c. $\frac{1}{2}$ | g. 2 |
| d. 1 | h. 0 |
- _____ 33. Let $f(x) = 8xe^{-4x^2}$, $x > 0$ be the probability density function of a random variable X . Find the median of the probability density function f .
- | | |
|----------------------------|-----------------------------|
| a. $\frac{\ln\sqrt{2}}{2}$ | e. $\frac{\ln 2}{2}$ |
| b. $\frac{\ln\sqrt{3}}{2}$ | f. $\frac{\sqrt{\ln 2}}{2}$ |
| c. $\frac{1}{2}$ | g. $\frac{\sqrt{\ln 2}}{4}$ |
| d. $\frac{2}{3}$ | h. $\frac{1}{4}$ |

Short Answer

34. Find the length of the curve $y = f(x)$, $0 \leq x \leq 2$, if $f'(x) = \sqrt{4x^2 + 2x - \frac{3}{4}}$
35. Find the length of the curve $y = x^3$, $1 \leq x \leq 3$, using a graphing calculator to evaluate the integral
36. Find the length of $y = \ln(\sin x)$ for $\frac{\pi}{6} \leq x \leq \frac{\pi}{3}$
37. Set up, but do not evaluate, an integral for the length of $y = x^4 - x^2$, $-1 \leq x \leq 2$

38. Set up, but do not evaluate, an integral for the length of $y = \tan x$, $0 < x < \frac{\pi}{4}$
39. Find the length of the curve $3x = 2y^{\frac{3}{2}}$, $(0,0)$ to $(\frac{2}{3}, 1)$.
40. Find the distance traveled by a particle with position $(x,y) = (\cos^2 t, \cos t)$ as t varies in the time interval $[0, 4\pi]$. Compare with the length of the curve.
41. If $x = \cos 2t$, $y = \sin^2 t$ and (x,y) represents the position of a particle, find the distance the particle travels as t moves from 0 to $\frac{\pi}{2}$.
42. Find the length of the curve $x = t^3 \cos t$, $y = t^3 \sin t$, $0 \leq t \leq 3$, using a graphing calculator to evaluate the integral.
43. The equation of a curve in parametric form is $x = 4 \cos 3t$, $y = 4 \sin 3t$. Find the arc length of the curve from $t = 0$ to $t = \frac{\pi}{8}$.
44. Find the length of the curve $x = \frac{1}{8}y^4 + \frac{1}{4}y^{-2}$, $1 \leq y \leq 2$.
45. Find the arc length of the curve $y = x^2 - \frac{1}{8} \ln x$, $1 \leq x \leq 3$.
46. Find the arc length of the curve $x = t \cos t - \sin t$, $y = t \sin t + \cos t$, $0 \leq t \leq \pi$.
47. Two people weighing 100 lb and 180 lb are at opposite ends of a seesaw 14 ft long. Where should the point of support be placed so that the seesaw will balance?
48. Calculate the center of mass of a lamina with the given density and shape:

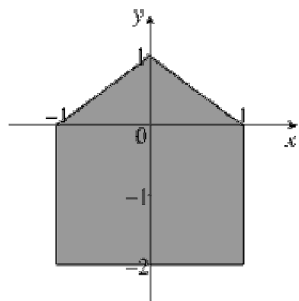
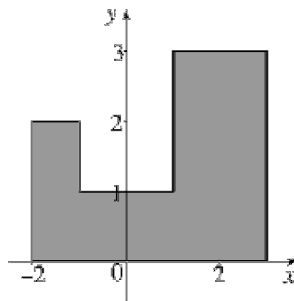
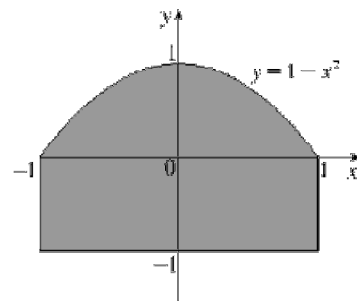
(a) $\rho = 4$ (b) $\rho = 1$ (c) $\rho = 1$ 

49. Find the centroid of the region bounded by $y = 1 - x^2$ and $y = 0$.

50. Find the center of mass of the lamina of uniform density δ bounded by $y = \sqrt{1-x^2}$ and x -axis.
51. Determine the centroid of the region bounded by the equation $y^2 - 9x = 0$ in the first quadrant between $x = 1$ and $x = 4$.
52. City B (population 4,000) is 10 miles north of City A (population 6,000), and City C (population 5,000) is 30 miles east of City B . Where is the best place to locate a super market serving the people in these cities?
53. Find the centroid of the region bounded by $y = \sin x$, $y = 0$ and $0 \leq x \leq \pi$.
54. Find the centroid of the region bounded by $y = \cos x$, $y = 0$ and $0 \leq x \leq \frac{\pi}{2}$.
55. The marginal revenue from selling x items is $90 - 0.02x$. The revenue from the sale of the first 100 items is \$8800. What is the revenue from the sale of the first 200 items?
56. The marginal revenue for a company when sales are q units is given by $\frac{dR}{dq} = 12 - 0.06q$. Find the increase in revenue when the sales level increases from 100 to 200 units.
57. The marginal cost for a company is given by $C'(q) = 2 - 0.01q + 0.005q^2$ where q is the number of units produced. What is the total cost to raise production from 100 to 200 units?
58. The marginal cost for the production of the new Super Widget at Widget International is give by $C'(q) = 15 - 0.0002q$, whereas the marginal revenue is $R'(q) = 20 - 0.003q$, where in both cases q represents the number of units produced.
- (a) Determine the change in profits when sales are increased from 700 to 1700 units.
- (b) What is the change in profit when sales increase from 1700 to 2700 units? Discuss your answer.
59. The demand function for a certain commodity is $p = 5 - \frac{x}{10}$. Find the consumer's surplus when the sales level is 30. Illustrate by drawing the demand curve and identifying the consumer's surplus as an area.
60. The demand function for producing a certain commodity is given by $p = 1000 - 0.1x - 0.0001x^2$. Find the consumer surplus when the sale level is 500.
61. A manufacture has been selling 1000 ceiling fans at \$60 each. A market survey indicates that for every \$10 that price is reduced, the number of sets sold will increase by 100. Find the demand function and calculate the consumer surplus when the selling price is set at \$50.
62. The demand function for a certain commodity is $p(x) = \frac{1800}{(x+5)^2}$. Find the consumer surplus when the selling price is \$18.

63. The demand function for a certain commodity is $p(x) = \frac{1800}{(x+5)^2}$, and consumer surplus is 90. What should be the selling price?
64. The dye dilution method is used to measure cardiac output with 6 mg of dye. The dye concentrations, in mg/L, are modeled by $c(t) = \frac{1}{15}t(15-t)$, $0 \leq t \leq 15$, where t is measured in seconds. Find the cardiac output.
65. The following table shows the relationship between price and demand for milk produced in a large dairy.

q (billions of pounds of milk per year)	45	50	55	60	65	70	75
p (price in dollars per pound)	1.00	0.90	0.80	0.70	0.60	0.50	0.40

Determine the consumer's surplus when the sales quantity is 65 billion pounds of milk in a year. Illustrate your answer by drawing the corresponding demand curve and the identifying the consumer's surplus as a region.

66. (a) Show that $f(x) = \begin{cases} 4x + 12x^2 & \text{if } 0 \leq x \leq \frac{1}{2} \\ 0 & \text{otherwise} \end{cases}$ is the probability density function of a random variable.
- (b) What is the mean for this distribution?
- (c) Calculate the median of f
67. (a) Show that $p(x) = \begin{cases} (2-k)x^{-3+k} & \text{if } x \geq 1 \\ 0 & \text{otherwise} \end{cases}$ where k is fixed and $0 < k < 1$ is a probability density function.
- (b) What is the mean for this distribution?
- (c) Calculate the median of p

68. (a) Explain why the function defined by the graph below is a probability density function.

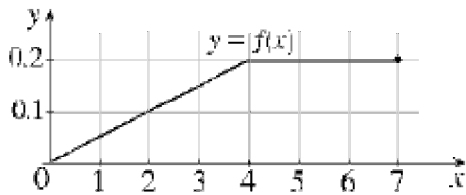

- (b) Use the graph to find the following probabilities:

- (i) $P(x < 2)$
(ii) $P(2 \leq x \leq 5)$

- (c) Calculate the median for this distribution.

69. Assume the daily consumption of electric power (in millions of kilowatt-hours) of a certain city

$$\text{has the probability density } p(x) = \begin{cases} \frac{1}{9}xe^{-\frac{x}{3}} & \text{if } x \geq 0 \\ 0 & \text{if } x < 0 \end{cases}$$

If the city's power plant has a daily capacity of 12 million kilowatt-hours, what is the probability that the available power supply will be inadequate on any given day?

70. Let $f(t) = 0.2e^{-2t}$, $t \geq 0$ be the probability density function of a random variable T , where t is the time that a customer spends in line at teller's window before being served. What is the probability that a customer will wait more than 10 minutes?
71. Let $f(t) = 0.2e^{-2t}$, $t \geq 0$ be the probability density function of a random variable T , where t is the time that a customer spends in line at teller's window before being served. What is mean of the probability density function?
72. Let $f(t) = 0.2e^{-2t}$, $t \geq 0$ be the probability density function of a random variable T , where t is the time that a customer spends in line at teller's window before being served. What is median of the probability density function?

73. Suppose that the mileage (in thousands of miles) which car owners can obtain from a certain kind of tire has

$$\text{the probability density } p(x) = \begin{cases} \frac{1}{100} \cdot e^{-\frac{x}{100}} & \text{if } x \geq 0 \\ 0 & \text{if } x < 0 \end{cases}$$

Find the probability that a tire chosen at random will last

- (a) at most 10,000 miles.
 - (b) between 15,000 and 25,000 miles.
 - (c) at least 30,000 miles.
74. Assume the weights of adult males are normally distributed with a mean weight of 150 pounds and a standard deviation of 20 pounds. Use Simpson's Rule or the Midpoint Rule to estimate the following:
- (a) What is the probability that an adult male chosen at random will weigh between 120 pounds and 180 pounds?
 - (b) What percentage of the adult male population weighs more than 200 pounds?
75. IQ scores are assumed to be normally distributed with a mean $\mu = 100$ and standard deviation $\sigma = 15$. Use either Simpson's Rule or the Midpoint Rule to approximate the probability that a person selected at random from the general population will have an IQ score
- (a) between 70 and 130.
 - (b) over 130.

76. Let $f(x) = \begin{cases} \frac{k \ln x}{x^4} & \text{if } x > 1 \\ 0 & \text{otherwise} \end{cases}$

- (a) Find k so that f can serve as the probability density function of a random variable X .
 - (b) Find $P(X > e)$.
 - (c) Find the mean.
77. The density function for the life of a certain type of battery is modeled by $p(t) = 0.2e^{-0.2t}$, $t > 0$ and is measured in months.
- (a) What is the probability that a battery will wear out during the first month of use?
 - (b) What is the probability that a battery is functioning for more than 12 months?

78. The density function for the life of a certain type of battery is modeled by $p(t) = 0.2e^{-0.2t}$, $t > 0$ and is measured in months.
- (a) Find the median life of the batteries.
 - (b) Find the mean life of the batteries.
 - (c) Sketch the graph of the density function showing the median and mean.
79. The density function for the waiting time at a bank is modeled by $p(t) = 0.1e^{-0.1t}$, $t > 0$ and is measured in minutes.
- (a) What is the probability that a customer will be served within the first 5 minutes?
 - (b) What is the probability that a customer has to wait for more than 15 minutes?
80. The density function for the waiting time at a bank is modeled by $p(t) = 0.1e^{-0.1t}$, $t > 0$ and is measured in minutes.
- (a) Find the median waiting time.
 - (b) Find the mean waiting time.
 - (c) Sketch the graph of the density function showing the median and mean.

**104 Ch. 9 Problems
Answer Section****MULTIPLE CHOICE**

- | | |
|------------|--------|
| 1. ANS: B | PTS: 1 |
| 2. ANS: E | PTS: 1 |
| 3. ANS: A | PTS: 1 |
| 4. ANS: F | PTS: 1 |
| 5. ANS: F | PTS: 1 |
| 6. ANS: E | PTS: 1 |
| 7. ANS: F | PTS: 1 |
| 8. ANS: D | PTS: 1 |
| 9. ANS: E | PTS: 1 |
| 10. ANS: H | PTS: 1 |
| 11. ANS: B | PTS: 1 |
| 12. ANS: A | PTS: 1 |
| 13. ANS: B | PTS: 1 |
| 14. ANS: A | PTS: 1 |
| 15. ANS: F | PTS: 1 |
| 16. ANS: C | PTS: 1 |
| 17. ANS: A | PTS: 1 |
| 18. ANS: A | PTS: 1 |
| 19. ANS: G | PTS: 1 |
| 20. ANS: C | PTS: 1 |
| 21. ANS: E | PTS: 1 |
| 22. ANS: H | PTS: 1 |
| 23. ANS: G | PTS: 1 |
| 24. ANS: B | PTS: 1 |
| 25. ANS: E | PTS: 1 |
| 26. ANS: F | PTS: 1 |
| 27. ANS: G | PTS: 1 |
| 28. ANS: D | PTS: 1 |
| 29. ANS: G | PTS: 1 |
| 30. ANS: A | PTS: 1 |
| 31. ANS: C | PTS: 1 |
| 32. ANS: C | PTS: 1 |
| 33. ANS: F | PTS: 1 |

SHORT ANSWER

34. ANS:

$$\int_0^2 \sqrt{\left(\sqrt{4x^2 + 2x - \frac{3}{4}}\right)^2 + 1} dx = 5$$

PTS: 1

35. ANS:

$$\int_1^3 \left(\sqrt{1+9x^4}\right) dx \approx 26.110$$

PTS: 1

36. ANS:

$$\ln\left(1 + \frac{2}{\sqrt{3}}\right)$$

PTS: 1

37. ANS:

$$L = \int_{-1}^2 \sqrt{16x^6 - 16x^4 + 4x^2 + 1} dx$$

PTS: 1

38. ANS:

$$L = \int_0^{\frac{\pi}{4}} \sqrt{1 + \sec^4 x} dx$$

PTS: 1

39. ANS:

$$\frac{2}{3} (2\sqrt{2} - 1)$$

PTS: 1

40. ANS:

$$\text{distance} = 4\sqrt{5} + 2\ln(\sqrt{5} + 2); \quad L = \sqrt{5} + \frac{1}{2}\ln(\sqrt{5} + 2)$$

PTS: 1

41. ANS:

$$\sqrt{5}$$

PTS: 1

42. ANS:

$$\int_0^3 t^2 \sqrt{t^2 + 9} dt \approx 34.033$$

PTS: 1

43. ANS:

$$\frac{3\pi}{2}$$

PTS: 1

44. ANS:

$$\frac{1}{2} \int_1^2 y^3 + y^{-3} dy = \frac{33}{16}$$

PTS: 1

45. ANS:

$$\frac{1}{8} \ln 3 + 8$$

PTS: 1

46. ANS:

$$\frac{\pi^2}{2}$$

PTS: 1

47. ANS:

The point of support should be 9 feet from the 100 lb person.

PTS: 1

48. ANS:

(a) $\left(0, -\frac{11}{15}\right)$

b) $\left(\frac{9}{10}, \frac{6}{5}\right)$

(c) $\left(0, -\frac{7}{50}\right)$

PTS: 1

49. ANS:

$$(\bar{x}, \bar{y}) = \left(0, \frac{2}{5}\right)$$

PTS: 1

50. ANS:

Center of mass $(0, \frac{4}{3\pi})$

PTS: 1

51. ANS:

(2.65, 2.41)

PTS: 1

52. ANS:

Let City A be at (0, 0) , City B at (0, 10) and City C at (30, 10)

$$\bar{x} = \frac{0+0+30 * 5000}{6000+4000+5000} = 10, \bar{y} = \frac{0+10 * 4000+10 * 5000}{6000+4000+5000} = 6$$

PTS: 1

53. ANS:

 $(\frac{\pi}{2}, \frac{\pi}{8})$

PTS: 1

54. ANS:

 $(\frac{\pi}{2} - 1, \frac{\pi}{8})$

PTS: 1

55. ANS:

\$17, 500

PTS: 1

56. ANS:

\$300

PTS: 1

57. ANS:

\$11,716.60

PTS: 1

58. ANS:

(a) \$1640

(b) -\$1160. The company should change its production level.

PTS: 1

59. ANS:
\$45

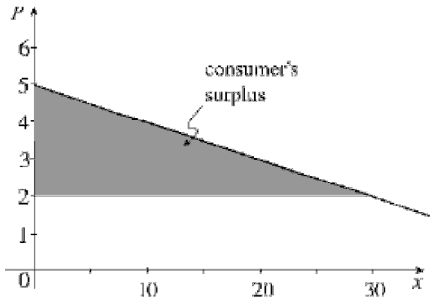

PTS: 1

60. ANS:
20,833.3

PTS: 1

61. ANS:
Demand function $p(x) = 160 - 0.1x$, Consumer surplus = \$60,500

PTS: 1

62. ANS:
 $18 = \frac{1800}{(x+5)^2} \Rightarrow x = 5; \int_0^5 \frac{1800}{(x+5)^2} - 18 dx = 90$

PTS: 1

63. ANS:
Solve for P, such that $\int_0^P \frac{1800}{(x+5)^2} - \frac{1800}{(P+5)^2} dx = 90 \Rightarrow \frac{3}{20} = \frac{2P+5}{(P+5)^2} \Rightarrow$
 $3P^2 - 10P - 25 = 0 \Rightarrow P \Rightarrow 5 \Rightarrow$ The selling price is $p(5) = 18$

PTS: 1

64. ANS:
0.16 L/sec

PTS: 1

65. ANS:
\$42.25

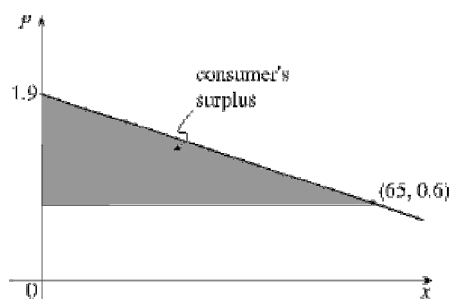

PTS: 1

66. ANS:

- (a) $\int_{-\infty}^{\infty} f(x) dx = \int_0^{\frac{1}{2}} 4x + 12x^2 dx = 1$
 (b) $\frac{17}{48}$
 (c) About 0.3774

PTS: 1

67. ANS:

- (a) $\int_{-\infty}^{\infty} p(x) dx = \int_1^{\infty} (2-k)x^{-3+k} dx = 1$
 (b) $\frac{2-k}{1-k}$
 (c) $2^{\frac{1}{2}-k}$

PTS: 1

68. ANS:

- (a) $\int_{-\infty}^{\infty} f(x) dx = 1$
 (b) (i) 0.1
 (ii) 0.5
 (c) 4.5

PTS: 1

69. ANS:

$$5 \cdot e^{-4} \approx 0.09$$

PTS: 1

70. ANS:

$$\int_{10}^{\infty} 0.2e^{-2t} dt = 0.135$$

PTS: 1

71. ANS:

$$\int_0^{\infty} 0.2te^{-2t} dt = 5$$

PTS: 1

72. ANS:

$$\int_m^{\infty} 0.2e^{-2t} dt = 0.5 \Rightarrow m = 5 \ln 2$$

PTS: 1

73. ANS:

$$(a) 1 - \frac{1}{e^{100}}$$

$$(b) \frac{1}{e^{150}} - \frac{1}{e^{250}} \approx 7 \times 10^{-66}$$

$$(c) \frac{1}{e^{300}}$$

PTS: 1

74. ANS:

(a) About 0.87

(b) About 0.006

PTS: 1

75. ANS:

(a) About 0.9544

(b) About 0.0228

PTS: 1

76. ANS:

(a) $k = 9$

$$(b) \frac{4}{e^3} \approx 0.199$$

$$(c) \frac{9}{4}$$

PTS: 1

77. ANS:
 (a) About 0.181
 (b) About 0.09

PTS: 1

78. ANS:
 (a) $5 \ln 2 \approx 3.466$
 (b) 5 months
 (c)

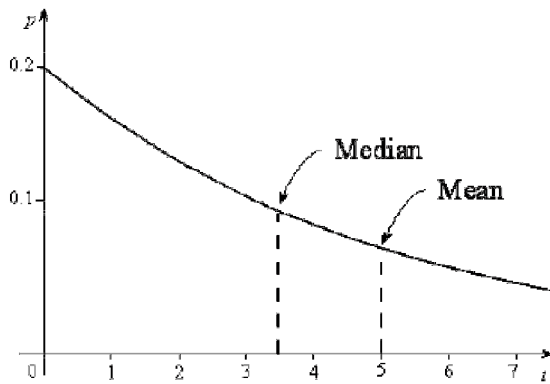

PTS: 1

79. ANS:
 (a) About 0.39
 (b) About 0.22

PTS: 1

80. ANS:
 (a) $10 \ln 2 \approx 6.93$ minutes
 (b) 10 minutes
 (c)

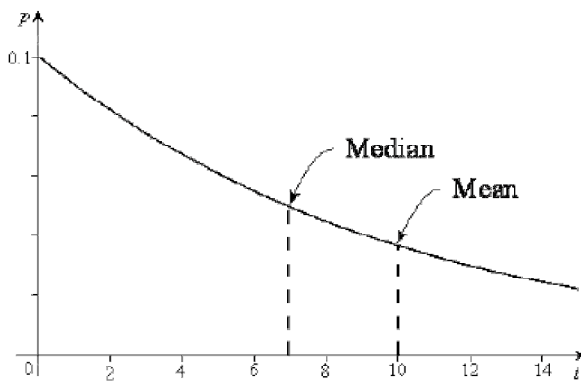

PTS: 1